



Proudly Distributed By

TRIDENT AUSTRALIA
FLUID SYSTEMS & COMPONENTS

OPERATION

The Ruelco 10A1 MP-2 relay is a pilot operated, spring return manual relay. It operates as a 3-way, block-and-bleed, normally closed valve with a palm knob for position indication and manual operation. In the closed position, the inlet signal will be blocked from reaching the outlet port, until the knob is manually pulled into service. The detent will allow the relay to maintain this state until a pilot signal becomes present. Once in this configuration, the relay is armed and will shut closed, venting the outlet pressure, with a drop in pilot signal or a manual push on the knob. The snap acting feature allows the relay to shut quickly with a minimal loss of pilot pressure. The relay will remain closed until the knob is manually pulled into service again.

FEATURES

- 316 stainless steel construction (models to N.A.C.E. MR0175 available)
- Large Cv factor assures fast system response
- Lock closed design prevents relay from automatically opening
- Design minimizes malfunctions due to supply system debris
- Inconel X-750 springs assures dependability in most corrosive environments

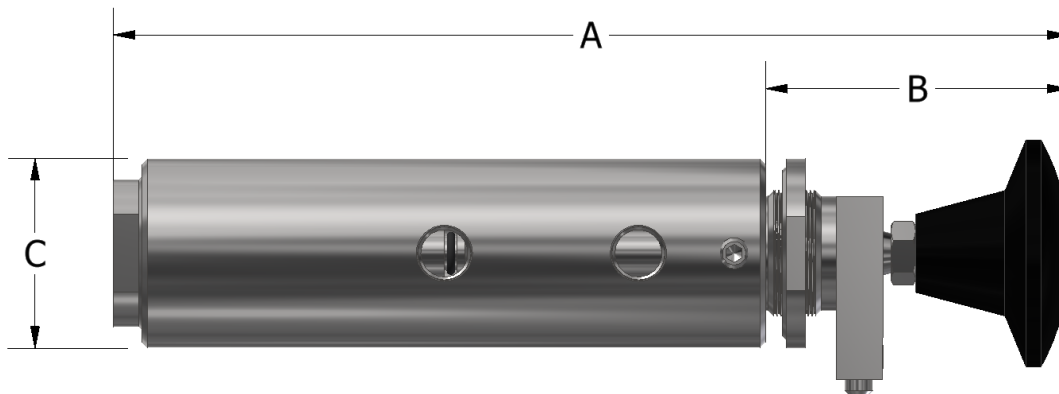

MP-2 N.C. MANUAL RESET RELAY

DIMENSIONS

A (CLOSED / OPEN)	7.54" / 7.91" (191.5 / 201 mm)
B (CLOSED / OPEN)	2.36" / 2.73" (60 / 69.3 mm)
C	1.50" (38.1 mm)
CONNECTION PORT SIZES	1/4" FNPT
PANEL MOUNT HOLE	1.0" (25.4 mm)
MAXIMUM PANEL THICKNESS	.18" (4.6 mm)
WEIGHT	2.5 LBS (1.14 KG)

PHONE: 504-340-0055
FAX: 504-340-0056
EMAIL: SALES@RUELCO.COM

1209 DISTRIBUTORS ROW
NEW ORLEANS, LA 70123



SPECIFICATIONS

MAXIMUM WORKING PRESSURE	250 PSI (17.2 BAR)
MAXIMUM PILOT CAP PRESSURE	125 PSI (8.6 BAR)
AMBIENT TEMPERATURE RANGE	-20 TO 250° F -29 TO 122° C
MINIMUM PILOT PRESSURE TO HOLD RELAY OPEN	27 PSI (1.9 BAR) WITH 20 PSI SPRING 35 PSI (2.4 BAR) WITH 30 PSI SPRING
Cv FACTOR	1.7

REPAIR KIT

- 10-013-0B0

OTHER TEMPERATURE RANGES AND SEAL COMPOUNDS AVAILABLE UPON REQUEST

ORDERING CODE

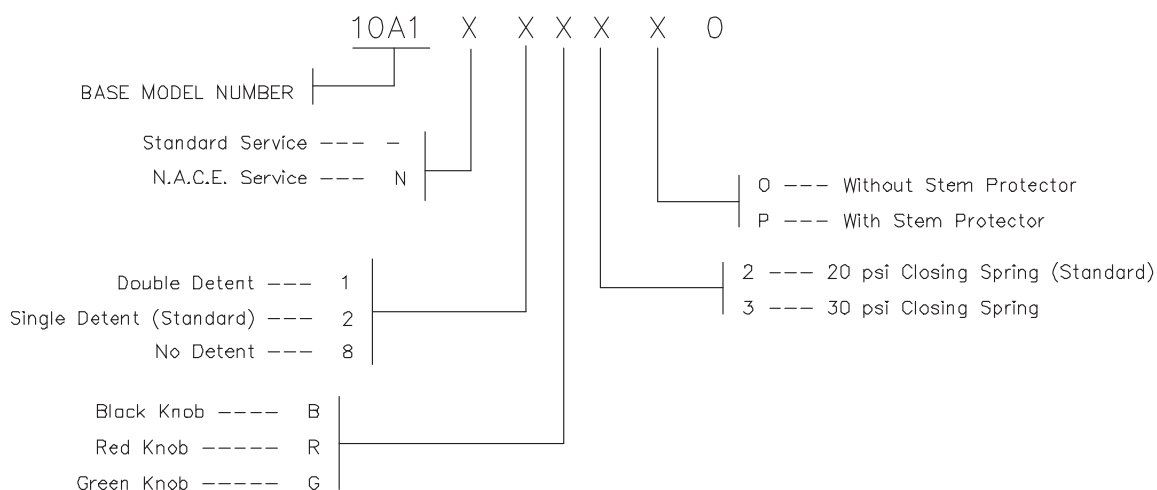

MP-2 N.C. MANUAL RESET RELAY

PHONE: 504-340-0055
FAX: 504-340-0056
EMAIL: SALES@RUELCO.COM

1209 DISTRIBUTORS ROW
NEW ORLEANS, LA 70123



Proudly Distributed By

TRIDENT AUSTRALIA
FLUID SYSTEMS & COMPONENTS

OPERATION

The Ruelco 10A1 MP-2H hydraulic relay is a pilot operated, spring return manual relay. It operates as a 3-way, block-and-bleed, normally closed valve with a palm knob for position indication and manual operation. In the closed position, the inlet signal will be blocked from reaching the outlet port, until the knob is manually pulled into service. The detent will allow the relay to maintain this state until a pilot signal becomes present. Once in this configuration, the relay is armed and will shut closed, venting the outlet pressure, with a drop in pilot signal or a manual push on the knob. The snap acting feature allows the relay to shut quickly with a minimal loss of pilot pressure. The relay will remain closed until the knob is manually pulled into service again.

FEATURES

- 316 stainless steel construction (models to N.A.C.E. MR0175 available)
- Large Cv factor assures fast system response
- Lock closed design prevents relay from automatically opening
- Design minimizes malfunctions due to supply system debris
- Inconel X-750 springs assures dependability in most corrosive environments

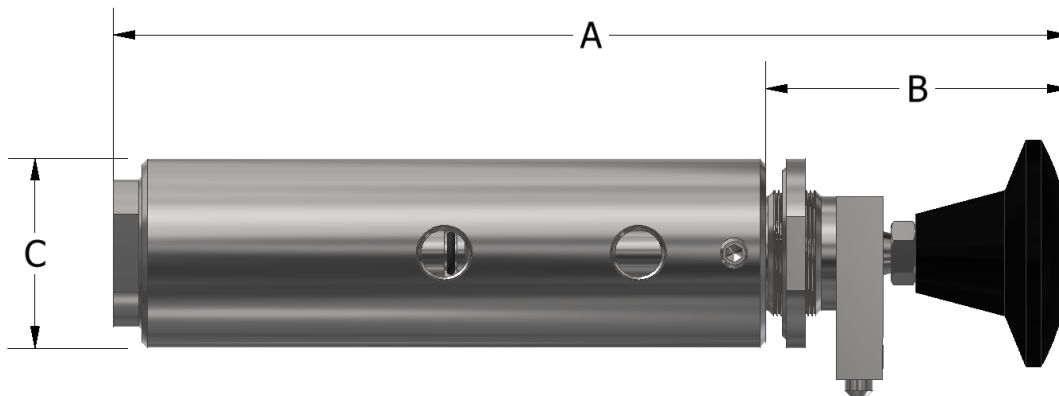

DIMENSIONS

A (CLOSED / OPEN)	7.54" / 7.91" (191.5 / 201 mm)
B (CLOSED / OPEN)	2.36" / 2.73" (60 / 69.3 mm)
C	1.50" (38.1 mm)
CONNECTION PORT SIZES	1/4" FNPT
PANEL MOUNT HOLE	1.0" (25.4 mm)
MAXIMUM PANEL THICKNESS	.18" (4.6 mm)
WEIGHT	2.5 LBS (1.14 KG)

PHONE: 504-340-0055
FAX: 504-340-0056
EMAIL: SALES@RUELCO.COM

1209 DISTRIBUTORS ROW
NEW ORLEANS, LA 70123

MP-2H N.C. MANUAL RESET RELAY



Proudly Distributed By

TRIDENT AUSTRALIA
FLUID SYSTEMS & COMPONENTS

SPECIFICATIONS

MAXIMUM WORKING PRESSURE	150 PSI (10.3 BAR)
MAXIMUM PILOT CAP PRESSURE	125 PSI (8.6 BAR)
AMBIENT TEMPERATURE RANGE	-20 TO 250° F -29 TO 122° C
MINIMUM PILOT PRESSURE TO HOLD RELAY OPEN	65 PSI (4.5 BAR)
Cv FACTOR	1.7

REPAIR KIT

- 10-013-0B0

OTHER TEMPERATURE RANGES AND SEAL COMPOUNDS AVAILABLE UPON REQUEST

MP-2H N.C. MANUAL RESET RELAY

ORDERING CODE

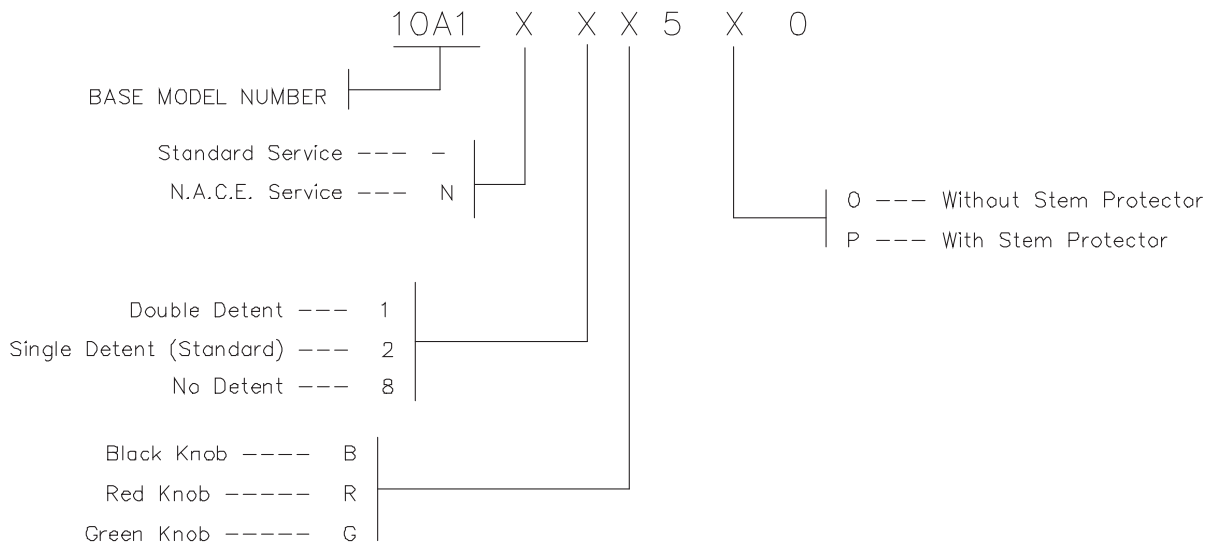

PHONE: 504-340-0055
FAX: 504-340-0056
EMAIL: SALES@RUELCO.COM

1209 DISTRIBUTORS ROW
NEW ORLEANS, LA 70123



Proudly Distributed By

TRIDENT AUSTRALIA
FLUID SYSTEMS & COMPONENTS

OPERATION

The Ruelco 10A2 MP-2 relay is a pilot operated, spring return manual relay. It operates as a 3-way, block and bleed, normally open valve with a palm knob for position indication and manual operation. In the open position, the inlet signal will flow to the outlet port, until the knob is manually pulled into service. The detent will allow the relay to maintain this state until a pilot signal becomes present. Once in this configuration, the relay is armed and will reopen, allowing inlet pressure to the outlet port, with a drop in pilot signal or a manual push on the knob. The snap acting feature allows the relay to shut quickly with a minimal loss of pilot pressure. The relay will remain open until the knob is manually pulled into service again.

FEATURES

- 316 stainless steel construction (models to N.A.C.E. MR0175 available)
- Large Cv factor assures fast system response
- May be used in pneumatic or hydraulic systems
- Lock Closed design prevents relay from automatically opening
- Design minimizes malfunctions due to supply system debris
- Inconel X-750 springs assures dependability in most corrosive environments

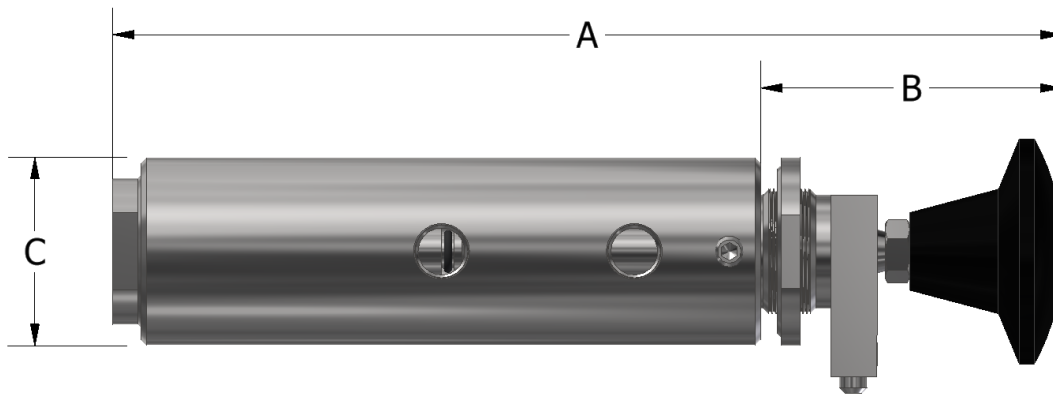

DIMENSIONS

A (CLOSED / OPEN)	7.54" / 7.91" (191.5 / 201 mm)
B (CLOSED / OPEN)	2.36" / 2.73" (60 / 69.3 mm)
C	1.50" (38.1 mm)
CONNECTION PORT SIZES	1/4" FNPT
PANEL MOUNT HOLE	1.0" (25.4 mm)
MAXIMUM PANEL THICKNESS	.18" (4.6 mm)
WEIGHT	2.5 LB (1.14 KG)

MP-2 N.O. MANUAL RESET RELAY

PHONE: 504-340-0055
FAX: 504-340-0056
EMAIL: SALES@RUELCO.COM

1209 DISTRIBUTORS ROW
NEW ORLEANS, LA 70123



SPECIFICATIONS

MAXIMUM WORKING PRESSURE	250 PSI (17.2 BAR)
MAXIMUM PILOT CAP PRESSURE	125 PSI (8.6 BAR)
AMBIENT TEMPERATURE RANGE	-20 TO 250° F -29 TO 122° C
MINIMUM PILOT PRESSURE TO HOLD RELAY OPEN	27 PSI (1.9 BAR) WITH 20 PSI SPRING 35 PSI (2.4 BAR) WITH 30 PSI SPRING
Cv FACTOR	1.7

REPAIR KIT

- 10-013-0B0

OTHER TEMPERATURE RANGES AND SEAL COMPOUNDS AVAILABLE UPON REQUEST

ORDERING CODE

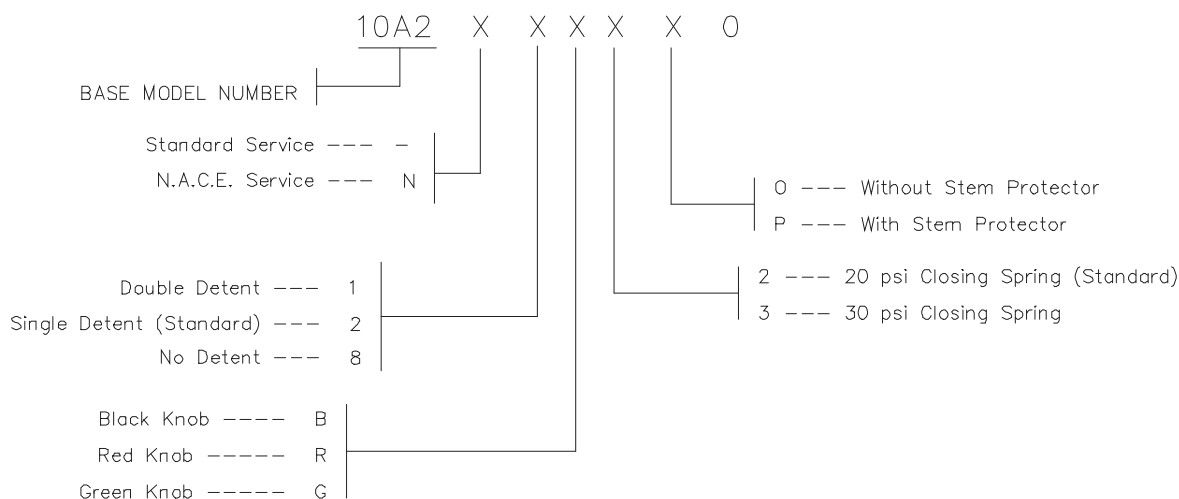

MP-2 N.O. MANUAL RESET RELAY

PHONE: 504-340-0055
FAX: 504-340-0056
EMAIL: SALES@RUELCO.COM

1209 DISTRIBUTORS ROW
NEW ORLEANS, LA 70123



Proudly Distributed By

TRIDENT AUSTRALIA
FLUID SYSTEMS & COMPONENTS

OPERATION

The Ruelco 12A1 AR-1 relay is a pilot operated, spring return automatic relay. It operates as a 3-way, block and bleed, normally closed valve with a palm knob for position indication and manual operation. In the closed position, the inlet signal will be blocked from reaching the outlet port, until a pilot signal becomes present. Once in this configuration, the relay is armed and will shut closed, venting the outlet pressure, with a drop in pilot signal or a manual push on the knob. The snap acting feature allows the relay to shut quickly with a minimal loss of pilot pressure. The relay will reopen if the knob is manually pulled into service or if the pilot supply once again becomes present.

FEATURES

- 316 stainless steel construction (models to N.A.C.E. MR0175 available)
- Large Cv factor assures fast system response
- Design minimizes malfunctions due to supply system debris
- Inconel X-750 springs assures dependability in most corrosive environments

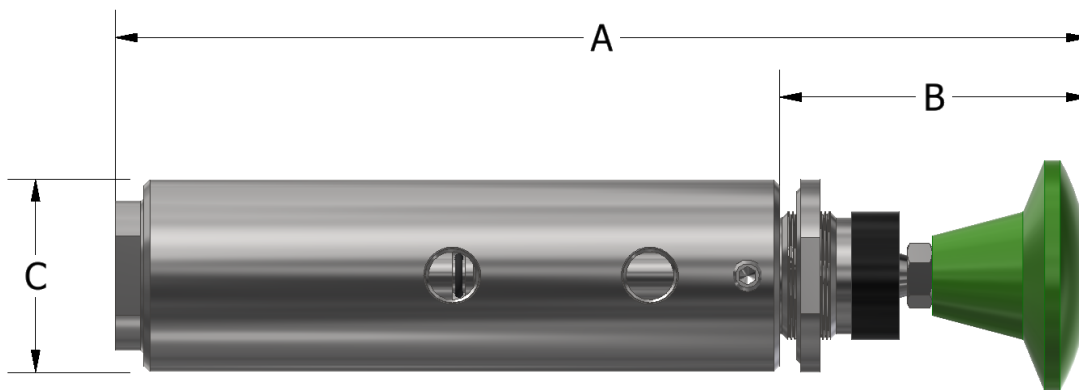

DIMENSIONS

A (CLOSED / OPEN)	7.54" / 7.91" (191.5 / 201 mm)
B (CLOSED / OPEN)	2.36" / 2.73" (60 / 69.3 mm)
C	1.50" (38.1 mm)
CONNECTION PORT SIZES	1/4" FNPT
PANEL MOUNT HOLE	1.0" (25.4 mm)
MAXIMUM PANEL THICKNESS	.18" (4.6 mm)
WEIGHT	2.5 LBS (1.14 KG)

AR-1 N.C. AUTOMATIC RESET RELAY

PHONE: 504-340-0055
FAX: 504-340-0056
EMAIL: SALES@RUELCO.COM

1209 DISTRIBUTORS ROW
NEW ORLEANS, LA 70123



SPECIFICATIONS

MAXIMUM WORKING PRESSURE	250 PSI (17.2 BAR)
MAXIMUM PILOT CAP PRESSURE	125 PSI (8.6 BAR)
AMBIENT TEMPERATURE RANGE	-20 TO 250° F -29 TO 122° C
MINIMUM PILOT PRESSURE TO HOLD RELAY OPEN	27 PSI (1.9 BAR) WITH 20 PSI SPRING 35 PSI (2.4 BAR) WITH 30 PSI SPRING
Cv FACTOR	1.7

REPAIR KIT

- 14-013-0A0

OTHER TEMPERATURE RANGES AND SEAL COMPOUNDS AVAILABLE UPON REQUEST

ORDERING CODE

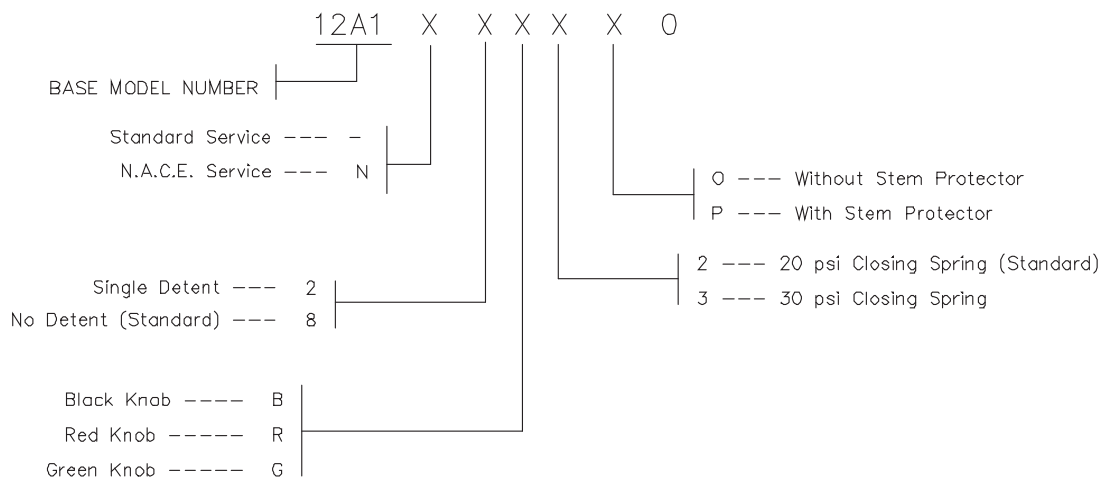

AR-1 N.G. AUTOMATIC RESET RELAY

PHONE: 504-340-0055
FAX: 504-340-0056
EMAIL: SALES@RUELCO.COM

1209 DISTRIBUTORS ROW
NEW ORLEANS, LA 70123



Proudly Distributed By

TRIDENT AUSTRALIA
FLUID SYSTEMS & COMPONENTS

OPERATION

The Ruelco 12A2 AR-1 Relay is a pilot operated, spring return automatic relay. It operates as a 3-way, block-and-bleed, normally open valve with a palm knob for position indication and manual operation. In the open position, the inlet signal will flow to the outlet port, until a pilot signal becomes present. Once in this configuration, the relay is armed and will reopen, allowing inlet pressure to the outlet port, with a drop in pilot signal or a manual push on the knob. The snap acting feature allows the relay to shut quickly with a minimal loss of pilot pressure. The relay will remain open until the knob is manually pulled into service or if the pilot supply once again becomes present.

FEATURES

- 316 stainless steel construction (models to N.A.C.E. MR0175 available)
- Large Cv factor assures fast system response
- Design minimizes malfunctions due to supply system debris
- Inconel X-750 springs assures dependability in most corrosive environments

AR-1 N.O. AUTOMATIC RESET RELAY

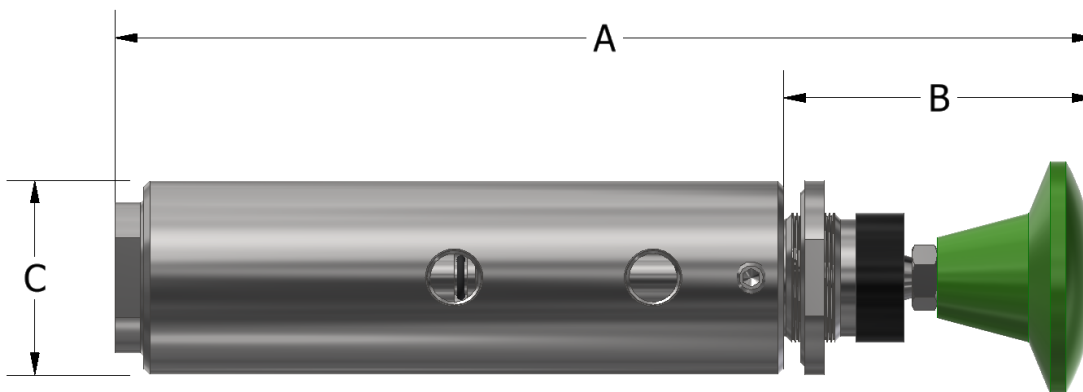

DIMENSIONS

A (CLOSED / OPEN)	7.54" / 7.91" (191.5 / 201 mm)
B (CLOSED / OPEN)	2.36" / 2.73" (60 / 69.3 mm)
C	1.50" (38.1 mm)
CONNECTION PORT SIZES	1/4" FNPT
PANEL MOUNT HOLE	1.0" (25.4 mm)
MAXIMUM PANEL THICKNESS	.18" (4.6 mm)
WEIGHT	2.5 LBS (1.14 KG)

PHONE: 504-340-0055
FAX: 504-340-0056
EMAIL: SALES@RUELCO.COM

1209 DISTRIBUTORS ROW
NEW ORLEANS, LA 70123



SPECIFICATIONS

MAXIMUM WORKING PRESSURE	250 PSI (17.2 BAR)
MAXIMUM PILOT CAP PRESSURE	125 PSI (8.6 BAR)
AMBIENT TEMPERATURE RANGE	-20 TO 250° F -29 TO 122° C
MINIMUM PILOT PRESSURE TO HOLD RELAY OPEN	27 PSI (1.9 BAR) WITH 20 PSI SPRING 35 PSI (2.4 BAR) WITH 30 PSI SPRING
Cv FACTOR	1.7

REPAIR KIT

- 14-013-0A0

OTHER TEMPERATURE RANGES AND SEAL COMPOUNDS AVAILABLE UPON REQUEST

ORDERING CODE

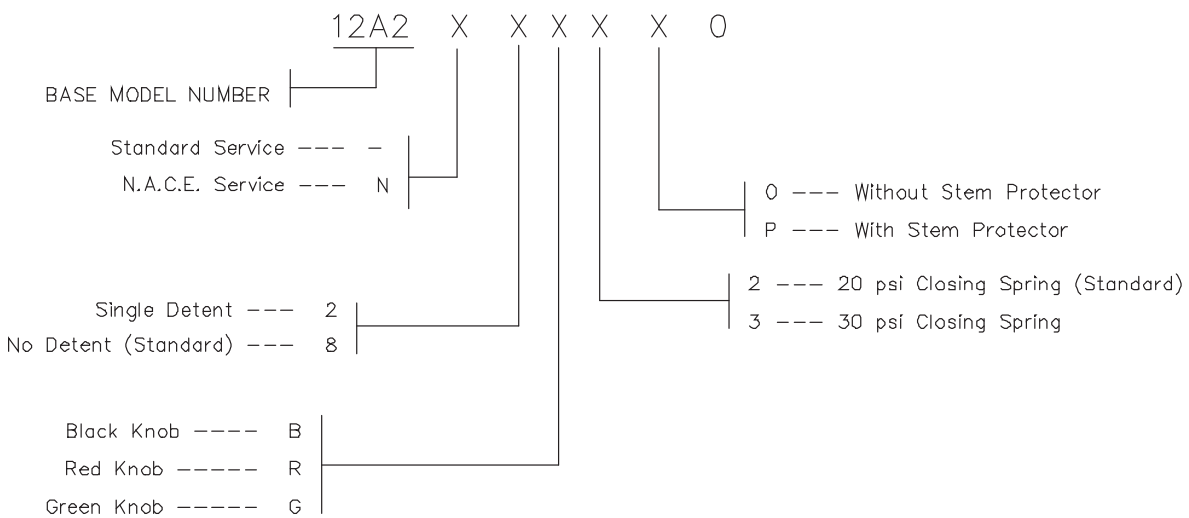

AR-1 N.O. AUTOMATIC RESET RELAY

PHONE: 504-340-0055
FAX: 504-340-0056
EMAIL: SALES@RUELCO.COM

1209 DISTRIBUTORS ROW
NEW ORLEANS, LA 70123



Proudly Distributed By

TRIDENT AUSTRALIA
FLUID SYSTEMS & COMPONENTS

OPERATION

The Ruelco 14A1 AR-2 Relay is a pilot operated, spring return automatic or manual relay. It operates as a 3-way, block-and-bleed, normally closed valve with a palm knob for position indication and manual operation. In Manual Mode, in the closed position, the inlet signal will be blocked from reaching the outlet port, until the knob is manually pulled into service. The detent will allow the relay to maintain this state until a pilot signal becomes present. Once in this configuration, the relay is armed and will shut closed, venting the outlet pressure, with a drop in pilot signal or a manual push on the knob. The snap acting feature allows the relay to shut quickly with a minimal loss of pilot pressure. The relay will remain closed until the knob is manually pulled into service again. In Automatic Mode, the relay will open with the presence of a pilot supply and close if the pilot supply is lost.

FEATURES

- 316 stainless steel construction (models to N.A.C.E. MR0175 available)
- Large Cv factor assures fast system response
- Design minimizes malfunctions due to supply system debris
- Inconel X-750 springs assures dependability in most corrosive environments

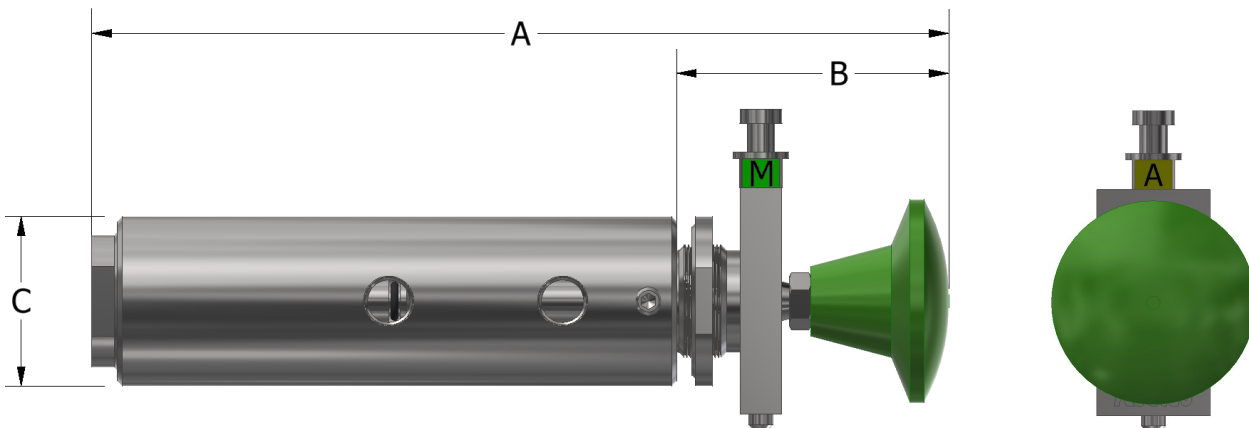

DIMENSIONS

A (CLOSED / OPEN)	7.54" / 7.91" (191.5 / 201 mm)
B (CLOSED / OPEN)	2.36" / 2.73" (60 / 69.3 mm)
C	1.50" (38.1 mm)
CONNECTION PORT SIZES	1/4" FNPT
PANEL MOUNT HOLE	1.0" (25.4 mm)
MAXIMUM PANEL THICKNESS	.18" (4.6 mm)
WEIGHT	2.5 LBS (1.14 KG)

PHONE: 504-340-0055
FAX: 504-340-0056
EMAIL: SALES@RUELCO.COM

1209 DISTRIBUTORS ROW
NEW ORLEANS, LA 70123

AR-2 N.C. AUTOMATIC/MANUAL RESET RELAY



SPECIFICATIONS

MAXIMUM WORKING PRESSURE	250 PSI (17.2 BAR)
MAXIMUM PILOT CAP PRESSURE	125 PSI (8.6 BAR)
AMBIENT TEMPERATURE RANGE	-20 TO 250° F -29 TO 122° C
MINIMUM PILOT PRESSURE TO HOLD RELAY OPEN	27 PSI (1.9 BAR) WITH 20 PSI SPRING 35 PSI (2.4 BAR) WITH 30 PSI SPRING
Cv FACTOR	1.7

REPAIR KIT

- 14-013-0A0

OTHER TEMPERATURE RANGES AND SEAL COMPOUNDS AVAILABLE UPON REQUEST

AR-2 N.C. AUTOMATIC / MANUAL RESET RELAY

ORDERING CODE

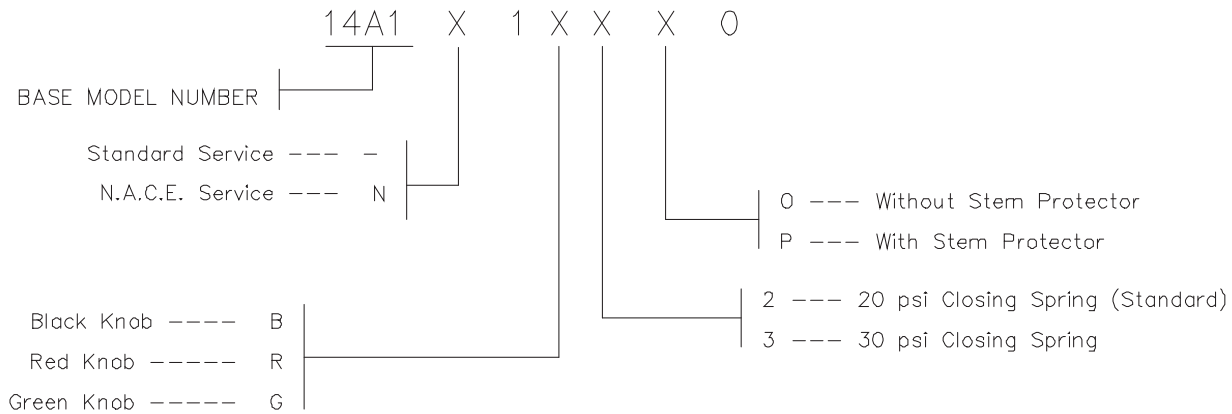

PHONE: 504-340-0055
FAX: 504-340-0056
EMAIL: SALES@RUELCO.COM

1209 DISTRIBUTORS ROW
NEW ORLEANS, LA 70123



Proudly Distributed By

TRIDENT AUSTRALIA
FLUID SYSTEMS & COMPONENTS

OPERATION

The Ruelco 14A2 AR-2 Relay is a pilot operated, spring return automatic or manual relay. It operates as a 3-way, block-and-bleed, normally open valve with a palm knob for position indication and manual operation. In Manual Mode, in the open position, the inlet signal will flow to the outlet port, until the knob is manually pulled into service. The detent will allow the relay to maintain this state until a pilot signal becomes present. Once in this configuration, the relay is armed and will reopen, allowing inlet pressure to the outlet port, with a drop in pilot signal or a manual push on the knob. The snap acting feature allows the relay to shut quickly with a minimal loss of pilot pressure. The relay will remain closed until the knob is manually pulled into service again. In Automatic Mode, the relay will open with the presence of a pilot supply and close if the pilot supply is lost.

FEATURES

- 316 stainless steel construction (models to N.A.C.E. MR0175 available)
- Large Cv factor assures fast system response
- Design minimizes malfunctions due to supply system debris
- Inconel X-750 springs assures dependability in most corrosive environments

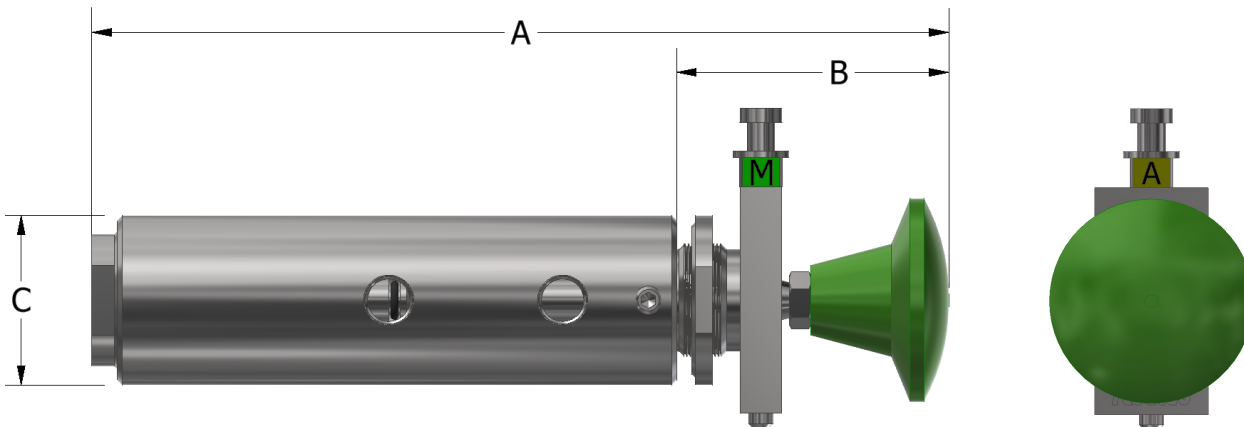

DIMENSIONS

A (CLOSED / OPEN)	7.54" / 7.91" (191.5 / 201 mm)
B (CLOSED / OPEN)	2.36" / 2.73" (60 / 69.3 mm)
C	1.50" (38.1 mm)
CONNECTION PORT SIZES	1/4" FNPT
PANEL MOUNT HOLE	1.0" (25.4 mm)
MAXIMUM PANEL THICKNESS	.18" (4.6 mm)
WEIGHT	2.5 LBS (1.14 KG)

PHONE: 504-340-0055
FAX: 504-340-0056
EMAIL: SALES@RUELCO.COM

1209 DISTRIBUTORS ROW
NEW ORLEANS, LA 70123

AR-2 N.O. AUTOMATIC/MANUAL RESET RELAY



SPECIFICATIONS

MAXIMUM WORKING PRESSURE	250 PSI (17.2 BAR)
MAXIMUM PILOT CAP PRESSURE	125 PSI (8.6 BAR)
AMBIENT TEMPERATURE RANGE	-20 TO 250° F -29 TO 122° C
MINIMUM PILOT PRESSURE TO HOLD RELAY OPEN	27 PSI (1.9 BAR) WITH 20 PSI SPRING 35 PSI (2.4 BAR) WITH 30 PSI SPRING
Cv FACTOR	1.7

REPAIR KIT

- 14-013-0A0

OTHER TEMPERATURE RANGES AND SEAL COMPOUNDS AVAILABLE UPON REQUEST

AR-2 N.O. AUTOMATIC / MANUAL RESET RELAY

ORDERING CODE

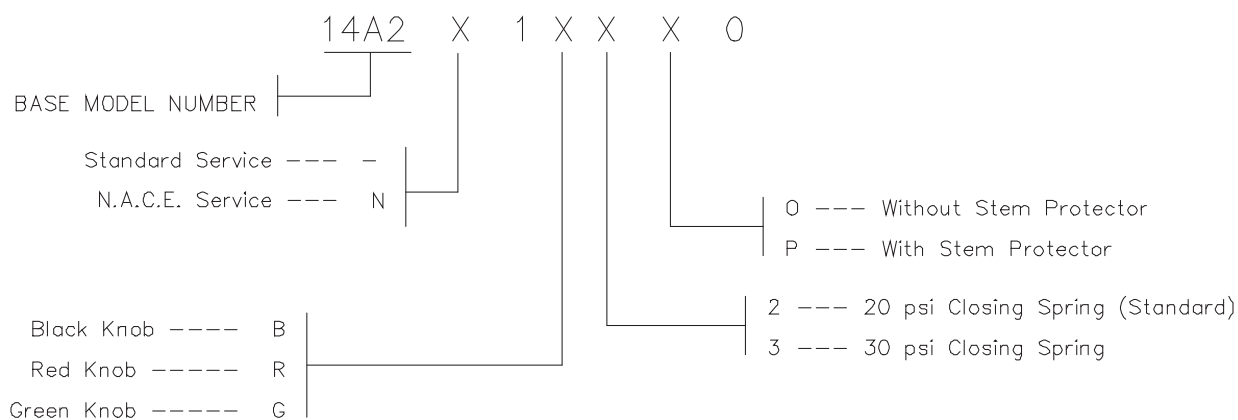

PHONE: 504-340-0055
FAX: 504-340-0056
EMAIL: SALES@RUELCO.COM

1209 DISTRIBUTORS ROW
NEW ORLEANS, LA 70123

PARTS LIST

ITEM	QUANTITY	DESCRIPTION	MATERIAL
1A	1	BLACK KNOB	PHENOLIC
1B	-	RED KNOB	PHENOLIC
1C	-	GREEN KNOB	PHENOLIC
2	1	LOCK NUT	316 ST. STL.
3A	1	DETENT ASSEMBLY	CF-8M AND 316 ST. STL.
3B	-	DOUBLE DETENT ASSEMBLY	316 ST. STL. AND 17-4 ST. STL.
3C	-	DETENT REPLACEMENT (NO DETENT)	DELTRIN
4	2	SCREW	316 ST. STL.
5	1	PANEL MOUNT NUT (OPTIONAL)	316 ST. STL.
6	3	SET SCREW	316 ST. STL.
7	1	MOUNTING HEAD	316 ST. STL.
8*	1	HEAD SEAL	NITRILE
9*	4	SHAFT SEAL	FLUOROCARBON
10	1	SHAFT ASSEMBLY	316 ST. STL.
11	1	BODY	316 ST. STL.
12A	1	20 PSI SPRING	INCONEL X-750
12B	-	30 PSI SPRING (OPTIONAL)	INCONEL X-750
13*	1	PISTON SEAL	NITRILE
14*	1	BASE SEAL	FLUOROCARBON
15	1	BASE	316 ST. STL.

*Indicates item(s) contained in the Repair Kit

PHONE: 504-340-0055
 FAX: 504-340-0056
 EMAIL: SALES@RUELCO.COM

1209 DISTRIBUTORS ROW
 NEW ORLEANS, LA 70123

RELAYS

STEM PROTECTOR

OPERATION

The optional Ruelco Stem Protector is designed to prevent debris such as ice or dust from allowing the relay to open or shut properly. The stem protector shields the entire spool from the exposed elements, yet still allows the operator to open and close the relay.

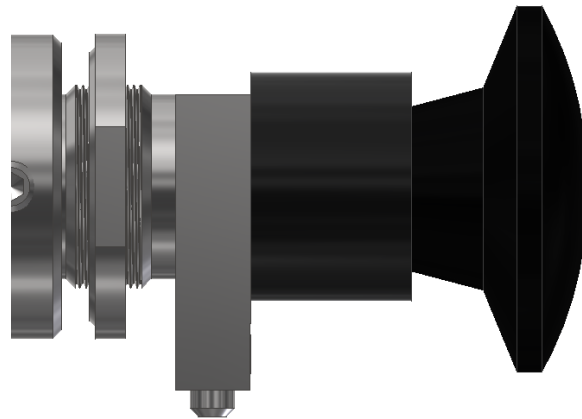

RELAY ACCESSORIES

PARTS LIST

ITEM	QUANTITY	DESCRIPTION	MATERIAL
1	1	STEM PROTECTOR HOUSING	DELRIN
2	1	STEM PROTECTOR WASHER	DELRIN
3#	1	STEM PROTECTOR SEAL	NITRILE

Indicates item(s) contained in the Repair Kit

REPAIR KIT

- 10-026-000

OTHER TEMPERATURE RANGES AND SEAL COMPOUNDS AVAILABLE UPON REQUEST

PHONE: 504-340-0055
FAX: 504-340-0056
EMAIL: SALES@RUELCO.COM

1209 DISTRIBUTORS ROW
NEW ORLEANS, LA 70123



DOUBLE DETENT

OPERATION

The optional Ruelco Double Detent is a replacement for the standard detent which allows for an extra layer of protection from accidental opening of the relay. The double detent requires the top knob to be pulled upward while the relay knob is pulled outward to open the relay. This will ensure that the relay is being intentionally opened.

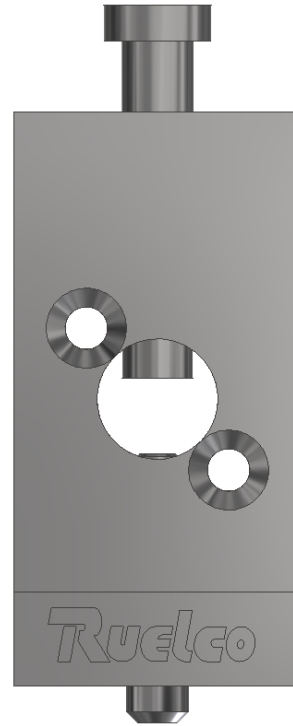

RELAY ACCESSORIES

PARTS LIST

ITEM	QUANTITY	DESCRIPTION	MATERIAL
1	1	DOUBLE DETENT BODY	316 ST. STL.
2	1	DETENT PIN	17-4 ST. STL.
3	2	DETENT SPRING	MUSIC WIRE
4	1	DOUBLE DETENT SLEEVE	316 ST. STL.
5	1	DOUBLE DETENT PIN	17-4 ST. STL.
6	1	DOUBLE DETENT KNOB	316 ST. STL.

PHONE: 504-340-0055
FAX: 504-340-0056
EMAIL: SALES@RUELCO.COM

1209 DISTRIBUTORS ROW
NEW ORLEANS, LA 70123